



Inscale Limited

IBS/IFS/IWI



Content

P.N. 7.00.6.6.0415, Rev 1, March 2018

1.0	INTRODUCTION	2
1.1	<i>Assembly instruction for IBS/IFS floor scale</i>	2
1.2	<i>Features</i>	2
1.3	<i>Power supply</i>	3
1.4	<i>Low battery warning</i>	3
2.0	LCD DISPLAY SYMBOLS	3
3.0	KEYBOARD FUNCTION	4
4.0	GENERAL PARAMETER	5
4.1	<i>Setting of sleep mode/automatic power off</i>	5
4.2	<i>Setting of the buzzer</i>	5
4.3	<i>Setting of auto backlight mode</i>	5
4.4	<i>Setting of check weighing function</i>	5
4.5	<i>Setting alert profiles in check weighing mode</i>	6
4.6	<i>Setting of color for alert backlight</i>	6
4.7	<i>Setting of date and time</i>	6
4.8	<i>Setting of auto shutdown protection level for low battery</i>	7
4.9	<i>Setting of brightness control of the back light</i>	7
4.10	<i>Setting of back light & RGB colour adjust</i>	7
5.0	CONNECTION OF INTERFACE	7
5.1	<i>Connection of load cell signal wire</i>	7
5.2	<i>Connection of RS-232</i>	8
6.0	MEANS OF POWER SUPPLY	8
6.1	<i>Rechargeable battery</i>	8
6.2	<i>AC/DC Adapter</i>	8
6.3	<i>Charging light</i>	8
7.0	COUNTING FUNCTION OPERATION	8
7.1	<i>How to enter in Counting weighing mode</i>	8
7.2	<i>How to operate</i>	8
8.0	PRINT OUT FORMAT	9
9.0	ERROR CODES	10

1. INTRODUCTION

1.1 ASSEMBLY INSTRUCTION FOR IBS/IFS FLOOR SCALE

If you have purchased IBS or IFS floor scales please follow the instructions:

1. Remove the platform from the packaging. Attach the 4 levelling feet if not already in place.
2. Attach the platform to pillar bracket using 4 screws provided with a cross head screwdriver if required. Tighten the pillar into the base bracket with the grub screws provided.
3. Make sure the platform cable is fed through and exiting the top of the pillar.
4. Take the indicator bracket and attach to the pillar neck adaptor using the 4 allen bolts provided.
5. Fit this to the top of the pillar making sure the cable is exiting through the cut out in the neck adaptor and tighten the grub screw in the pillar neck adaptor.
6. Attach the indicator to the bracket using the 2 thumb screws.
7. Connect the platform cable to the indicator cable.

You are now ready for use, please refer to the indicator user instructions.

1.2 FEATURES

1. Multiple weighing units: kg / lb / g.
2. Working temperature: -10°C~40°C
3. User-friendly design:
 - Auto calibration
 - AC / DC power supply
 - LCD display with auto back light
 - Auto power-off design to ensure the performance stability
 - Check weighing function with HI / OK / LO colorful back light and alert buzzer.
4. Variable calibration settings depending on the different calibration division.
 - Standard division (under 10,000 internal resolutions): Capacity and weight calibrations are available for accurate weighing.
 - High precision division (over 10,000 to 40,000 internal resolutions): Linearity, capacity and weight calibrations are available for accurate weighing.
5. Options
 - RS-232 interface
6. High performance in A/D converter
 - Conversion speed: 5-40 times / second

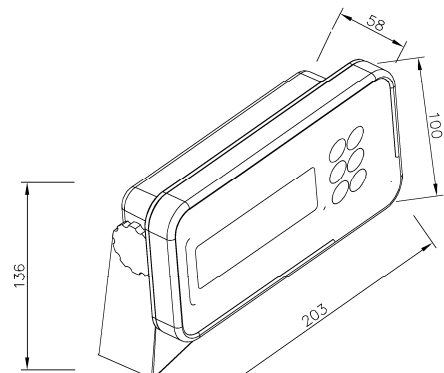

- Max resolution: n=10,000
 - Min resolution: 0.1uV
 - Supply current of load cell: < 200mA
 - Non-linearity: < 0.016% of full scale
 - Input range of load cell: 1.0 ~ 16mv/v
7. Humidity: ≤ 95%
 8. External dimension: 203×100×58mm
 9. Gross weight: 1.3 kg





1.3 POWER SUPPLY

1. Rechargeable battery: DC 6V / 1.2Ah
2. Adapter power: AC 100~220V, 50Hz / DC 12V, 500mA.

1.4 LOW BATTERY WARNING

Please note when  symbol is displayed on the window, the internal battery needs to be recharged. The indicator will power off automatically without recharging after the low battery symbol shows for 20 to 30 hours on the display. As a recommendation, the indicator should be fully recharged before using it again.



2. LCD DISPLAY SYMBOLS

o	Stable indication	Kg, lb, g	Weigh units
TR 	Tare mode		Gross weight
→0←	Zero indication		Net weight
	Charging light		Low Battery
HOLD	The reading is held with animal weigh function	HI/OK/LO	Check weighing indication

3. KEYBOARD FUNCTION

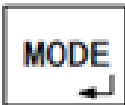

Keyboard Panel

	<p>Power switch key. The indicator will be turned on or off when pressing the key. Press and hold the key for 1.5 seconds, it will test-self until it is zero. When the Indicator is on, press key fast, it also shows “ bpt - -” about current capacity of battery.</p>
<p>TARE</p>	<p>Deduct the container weight. Press this key to deduct container weight and the net weight indication will be displayed.</p>
<p>ZERO</p>	<p>To re-zero the scale. Range of re-zero is $\pm 2\%$ of full scale.</p>
	<ul style="list-style-type: none"> * Allows switching of the weighing units whilst in weighing mode. * Switching the backlight to manual. * Press to confirm the setting when it is in setting menu or calibration mode.
<p>M+</p> 	<ul style="list-style-type: none"> * M+ Key for recalling the memory of accumulative weight. Accumulative data and weight will be displayed on the screen. Press [Zero] to clear accumulative weight and data. * Selective key when in setting menu.
<p>PRINT</p> 	<ul style="list-style-type: none"> * Press the key to print out the current weight and the weight will be added to accumulative weight. * Print out the memory while in accumulative mode (Press MR key first). * Selective key when in setting menu.

4. GENERAL PARAMETER

Please press and hold [MODE] and [Zero] keys for 3 second together and release until it displays =====.

4.1 SETTING OF SLEEP MODE / AUTOMATIC POWER OFF

The display shows OFF 0 meaning that the indicator is not in a sleep mode. The preset shut down time can be set from always on to auto off after 60 minutes. If there are no changes on weighing value and no operation on keyboard choose to disable auto off.

Press [MODE] to confirm and go to the next step. Press [PRINT] to adjust the auto off time in increments of 2 minutes for each press.

4.2 SETTING OF THE BUZZER

The display shows bP On or bP OFF.

Press [PRINT] to select "On" or "OFF" to turn on/off the buzzer. Not having buzzer on will help decrease power consumption and extend the battery life.

Press [MODE] to confirm and go to the next step.

4.3. SETTING OF AUTO BACK LIGHT MODE

The display shows Pr AB . **A** for back light mode. **B** for the effective time.

A=0, means switching the back light on manually. Press and hold [Mode] to turn on/off the back light.

A=1 Light-off while the reading is stable.

A=2 Light-off while it is in zero.

A=3 Light-off after the Date & time display.

A=4 Light-off after Company name, the date & time display.

B=1~9, means the effective time 1~9min. After this time the chosen back light mode will work.

Press [M+] & [PRINT] to select, press [MODE] to confirm and go to the next step.

4.4 SETTING OF CHECK WEIGHING FUNCTION

The indicator has a check weighing function which allows it to check weigh, making set point weighing quick and accurate. There is a multicolor back light function. The display shows HOL . To skip the function press [MODE] and go to the next step.

Press [M+] to enter setup menu.

Step 1: When XXXX kg & - HI - indication is showing, this allows you to set the highest limit. If indicator is over this weight, " HI " indication will show with a red back light.

Press [M+] & [PRINT] key to set the limit level, then press [MODE] to confirm and

go to the step 2.

Step 2: When & indication is showing, this allows you to set the lowest limit, if scale is under this weight, “LO” indication shows with a white back light.

Press **[M+]** & **[PRINT]** key to set the limit level, then press **[MODE]** to confirm and go to the next step.

For example: The desired weight is 100kg and the acceptable deviation value is ± 0.2 kg.

Step 1: Press **[M+]** & **[PRINT]** key to set highest weight 100.20kg, the screen will display , then press **[MODE]** to confirm and go to the Step 2.

Step 2: Press **[M+]** & **[PRINT]** key to set the lowest weight 100.10kg, the screen will display , then press **[MODE]** to confirm and go to the next step.

Step 3: After going back to normal weighing, load the items on the scale, if over or under these two points weight, the “HI” or “LO” indication will be showing with the alert buzzer and different back light colour to alert the user. But, when the weight is in the target range, the “OK” indication will show without alert buzz and with a green back light.

4.5. SETTING ALERT PROFILES IN CHECK WEIGHING MODE

This only works when the check weighing function is set.

The display shows .

X=0, means the indicator will keep checking and alert, even if the reading is unstable.

X=1, means the indicator will alert only after the reading is stable.

X=2~9, means the indicator will alert when the readings appear the same number of times that the parameter has been selected for. It happens even when the reading is unstable.

Press **[PRINT]** to select and press **[MODE]** to confirm and go to the next step.

4.6. SETTING OF COLOUR FOR ALERT BACK LIGHT

The user can select a customized back light colour for HI, OK, Low points, so that it's easy to recognize the check weighing alerts.

The display shows . High point colour back light. Press **[PRINT]** to select and press **[MODE]** to confirm and go to the next step.

The display shows . OK point colour back light. Press **[PRINT]** to select and press **[MODE]** to confirm and go to the next step.

The display shows . High point colour back light. Press **[PRINT]** to select and press **[MODE]** to confirm and finish setting and go to the next step.

4.7. SETTING OF DATE & TIME

The display shows .

Press **[M+]** & **[PRINT]** to set the date & time.

Press **[MODE]** to confirm and next step.

4.8. SETTING OF AUTO SHUTDOWN PROTECTION FOR LOW BATTERY

The display shows **PLO XX**. "XX" means the lowest percentage of battery capacity. When the capacity of battery is lower than the setting value, the indicator will shutdown and needs to be charged. This helps to increase the life of battery. The **default is "20%"**.

Press **[PRINT]** to select from "0~40" and press **[MODE]** to confirm and go to the next step.

4.9. SETTING OF BRIGHTNESS CONTROL OF THE BACK LIGHT

The display shows **LED X**. There are 0~8 levels of brightness, increasing by number. "5" is default value. The darker the back light, the longer battery life will be.

Press **[PRINT]** key to select the value. Press **[MODE]** to confirm value and go to the next step.

4.10. SETTING OF BACKLIGHT & RBG COLOR ADJUST

The display shows **rRG**. Press **[MODE]** confirm and exit to weighing mode.

Press **[→0←]** to set another colour and adjust the RGB for better display.

The display shows **C=xxx**. "xxx" for code of different colour of back light. Press **[MODE]** confirm and exit to weighing mode.

Press **[Zero]** to adjust the RGB value for a better display.

R=xxx, for red colour value.

G=xxx, for green colour value.

B=xxx, for blue colour value.

Press **[M+] & [PRINT]** to select the intensity and press **[MODE]** to finish the settings.

5. CONNECTION OF INTERFACE

5.1 CONNECTION OF LOAD CELL SIGNAL WIRE

For best performance, make sure the connection of the 5 pin plug to the 5 pin socket are firmly secured and tighten the screw.

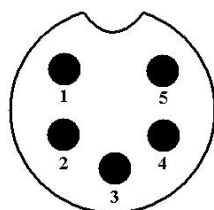

1: Pin +IN	+signal
2: Pin -IN	-signal
3: Pin AGND	shield
4: Pin +E, +S	+excitation, +feed back
5: Pin -E, +S	-excitation, -feed back

NOTE: For 6 pin load cell, please connect +E, +S and -E, -S in short circuit.

5.2 CONNECTION OF RS-232

RS-232 serial interface is a screw terminal.

6. MEANS OF POWER SUPPLY

6.1. RECHARGEABLE BATTERY

The rechargeable battery is 6V / 1.2Ah. The end of red line is positive pole, while the end of black line is negative pole. Connect the wiring terminals and tighten the screw up to fix battery securely. The rechargeable battery should be charged through adapter by plugging the adapter into power supply to achieve automatic charge.

6.2. AC/DC ADAPTER

Insert DC plug of the adapter, the specification is 12V/500mA, into the DC socket, insert the other end into mains socket and turn on the power supply.

In case there is no mains supply and the battery is used as a substitute, remember to pull out DC plug of the adapter, otherwise the indicator will not work.

6.3. CHARGING LIGHT

While the battery is charging, the charging light is lit. The colour of the light shows the status of battery if it is full or not: red light for low battery, yellow light for 80%, green light is full charged.

7. COUNTING FUNCTION OPERATION

Attention: In counting mode, the indicator disables the weight unit switching function.

This mode is used to indicate the number of pieces of an item that placed on the pan. To ensure accuracy, the parts that counted must be consistent in weight.

The indicator uses a sampling method to determine the average pieces weight of the items that counted.

7.1 How to enter in Counting weighing mode.

Press **[MODE]** to switch between standard weighing mode and counting mode.

7.2 How to operation

Step 1: Place the sample items on the pan/container all at once.

Step 2: When the weight display stable with STB indication.

Step3: Press **[MODE]** enter to Counting Mode. The screen displays **"0 pcs"** .

"XXXXX" means the number of items that placed in the pan. Press **[M+]** for 3 seconds and the "xxx pcs" will be showing.

Step 4: Press **[M+]** & **[PRINT]** key to input the sample number, then press **[MODE]** to confirm.

Step 5: Upload the sample unit and place the items on the pan that need to be counted. The screen displays the total pieces of items and “PCS” indication is on. If you need to set a new sample, repeat the same operation as above again.

For example: the sample weight is 200g, for 100pcs sample units.

Step 1: Place the 200g sample unit in the pan.

Step 2: Press **[M+]** enter counting mode and it displays “**0 pcs**”.

Step 3: Press **[M+]** & **[PRINT]** to input the sample number, and it displays “**00100 pcs**”.

Step 4: Press **[MODE]** to confirm and upload the sample unit.

Step 5: Loading the weight, say “400g”, the screen will show “**200 pcs**”.

Step 6: Press **[MODE]** to exit and change to standard weighing mode.

8. PRINT OUT FORMAT.

The indicator offered two kinds of print out format with a external printer. Date & time will be printed automatically.

Format A: Single weight printing.

2015-08-16 13:38
NO: 001
Weight: 10.00 kg

2015-08-16 13:40
Add: 003
Total: 30.00 kg

Format B: Triple weights printing.

2015-08-16 13: 38
NO: 001
G.W: 10.00 kg
N.W: 10.00 kg
T.W: 0.00 kg

2015-08-16 13:40
Add: 003
Total: 30.00 kg

9. ERROR CODES

The following are error codes when indicator has some problem:

Error 1: means calibration isn't working, the weight is too light or the division is too high.

Error 2: means wrong zero, check the load cell for damage.

Error 3: means displayed value exceed display range after unit change.

Error 4: means ISN=0

Error 5: means overload, loaded weight exceeds the full range.

Error 6: means cannot zero.

Error 7: means cannot tare.

Error 8: means cannot accumulate

Error 9: means cannot make the unit conversion.

Error 10: means no battery connection or the battery is damaged.

Error 11: means count value division is too high.

WEEE 2012/19/EU

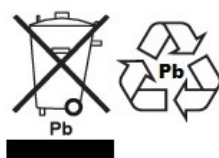

This device may not be disposed of in domestic waste. This also applies to countries outside the EU, per their specific requirements. Disposal of batteries (if fitted) must conform to local laws and restrictions.

Cet appareil ne peut être éliminé avec les déchets ménagers. L'élimination de la batterie doit être effectuée conformément aux lois et restrictions locales.

Dieses Gerät nicht mit dem Hausmüll entsorgt.

Dispositivo no puede ser desechado junto con los residuos domésticos

Dispositivo non può essere smaltito nei rifiuti domestici.

FCC / IC CLASS A DIGITAL DEVICE EMC VERIFICATION STATEMENT

NOTE: This equipment has been tested and found to comply with the limits for a Class A digital device, pursuant to Part 15 of the FCC rules and Canadian ICES-003/NMB-003 regulation. These limits are designed to provide reasonable protection against harmful interference when the equipment is operated in a commercial environment. This equipment generates, uses and can radiate radio frequency energy and, if not installed and used in accordance with the instruction manual, may cause harmful interference to radio communications. Operation of this equipment in a residential area is likely to cause harmful interference in which case the user will be required to correct the interference at his own expense..

WEEE COMPLIANCE



Sealed Lead Acid
Battery
Must be recycled
Properly

Any Electrical or Electronic Equipment (EEE) component or assembly of parts intended to be incorporated into EEE devices as defined by European Directive 2002/95/EEC must be recycled or disposed using techniques that do not introduce hazardous substances harmful to our health or the environment as listed in Directive 2002/95/EC or amending legislation. Battery disposal in Landfill Sites is more regulated since July 2002 by regulation 9 of the Landfill (England and Wales) Regulations 2002 and Hazardous Waste Regulations 2005. Battery recycling has become topical and the Waste Electrical and Electronic Equipment (WEEE) Regulations are set to impose targets for recycling.

Inscale Ltd. products are predominantly designed for the Laboratory, Educational, Medical, Retail and Industrial segments. The product range can be described as follows:

- Analytical and precision balances
- Compact and portable balances
- High capacity balances
- Moisture analysers / balances
- Mechanical scales
- Counting scales
- Digital weighing/Check-weighing Scales
- High performance platform scales
- Crane scales
- Medical scales
- Retail scales for price computing

For a complete listing of all Inscale products visit our website at

www.inscale.co.uk

© Copyright by Inscale Ltd. All rights reserved. No part of this publication may be reprinted or translated in any form or by any means without the prior permission of Inscale Ltd. Inscale Ltd. reserves the right to make changes to the technology, features, specifications and design of the equipment without notice. All information contained within this publication is to the best of our knowledge timely, complete and accurate when issued. However, we are not responsible for misinterpretations which may result from the reading of this material. The latest version of this publication can be found on our Website.

www.inscale.co.uk

Maidstone Road, Kingston, Milton Keynes,

Bucks, MK10 0BD, United Kingdom

Telephone: 0800 612 9007

VAT No: GB 936846676

E-Mail: sales@inscale.co.uk